

## KEN SHOULDERS, 1927-2013. A MAVERICK GENIUS.

The Man Who Made Black Holes.

Alan Smith, [www.lookingforheat.com](http://www.lookingforheat.com) November 2017

*“Ken’s brilliance will be missed in the scientific community as a visionary in the field of new energy exotic vacuum objects (EVO’s). He was a leader in this new frontier, but perhaps best known to the scientific community as the father of vacuum microelectronics.” Diane Meade (Family member)*

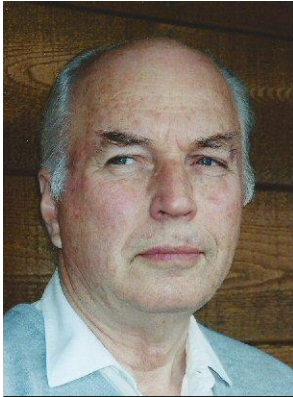

KEN SHOULDERS 1927 - 2013

### INTRODUCTION

Almost anyone who has spent time investigating ‘unlikely physics’ may have stumbled across mention of, or papers written by, the late Ken Shoulders. There are factors emerging now which may well bring renewed interest in the huge body of scientific work which forms his intellectual legacy. Shoulders has often been described by his peers as the ‘father’ of the domain known as ‘Vacuum Nano-electronics’. In part this is because over the last decade, prompted by concerns about climate change and rising energy costs there is in the phenomenon formerly known as ‘cold fusion’ now generally referred to as LENR. It seems likely that this field will benefit from a re-examination of Shoulders discoveries, particularly his work on EVO’s (Exotic Vacuum

Objects or ‘Charge Clusters’ - CC’s). These names are convenient labels used to categorise phenomena which some researchers (this author included) feel offer key insights into new and fundamentally different approaches to LENR and as yet unexploited ways of creating and transforming matter and energy ‘at table-top scale’.

### HIS EARLY YEARS

Born in Texas, Ken Shoulders scraped through high school with modest grades, begrudging time spent studying subjects he found boring in order to pursue his interests in electronics and aeronautics. Despite being a less than ideal student, he was clearly bright, and is remembered for his fondness and skill at dismantling and re-building things just to find out how they worked.

After high school he wanted to work in the rapidly expanding field of electronics, and never went to college. Beyond this point he educated not only himself, but others around him. Employers included Magnavox, Texas Instrument and even radio station WKWF in Florida. In 1955 Shoulders got a job on the research staff of the Computer Components and Systems Laboratory at MIT, where he worked with Dudley Allen Buck on developing thin-film cryotron integrated circuits. In 1958 he moved to California to work as ‘Senior Research Engineer’ under Charles Rosen at Stanford Research Institute (SRI), where he set up SRI’s microelectronics program. Early in his career there R&D carried out under Shoulders’ direct guidance led to the development of many novel or radically improved devices and systems, including the Quadrupole Spectrometer, vacuum systems for evaporation processes and he pioneered the multi-beam electron etching system used to create (amongst other things) the Spindt cathode array. It seems probable that this work on electron beams provided the insight and impetus for his later work on EVOs.

During his time in Menlo Park, Shoulders led a very ‘California’ kind of life, commuting to work on a Vespa scooter, and when not bogged down by project deadlines was dreaming about flying machines and other things. Ideas for these and more exotic technologies were

always taking shape in his ever active – and to be honest - visionary brain. It was this which led him into doing work for the CIA and others, always operating at the edges of what was then considered conventional. Ken Shoulders was a true maverick who never followed the herd, viewed by his peers with some awe for his intuitive grasp of new concepts, always happiest when thinking ‘outside the box’. He was an unorthodox kind of scientific genius who bubbled with wild ideas at an astounding rate, leading to him winning a fun vote at SRI which proclaimed him ‘the SRI researcher most likely to build a perpetual motion machine.’

Capp Spindt, a former colleague wrote:-

*“I just got the news that Ken Shoulders, the internationally recognized father of vacuum microelectronics and the guy that hired me at SRI in 1959 has died...He was not only my “boss”, but also a mentor, colleague, and friend – He was a true genius, and always way ahead of all of us in every way. We often couldn’t grasp or even understand what he envisioned or claimed to have seen, but over time it always turned out that he was right... A most amazing person.”*



Promotional handout for the Gyrodyne Convertiplane, an aircraft Shoulders believed could change how people commuted to work.  
*Kenneth R. Shoulders Papers, CHF Collections*

By the 1960's Shoulders had developed preliminary sketches and specifications for a flying car, the Gyrodyne Convertiplane, the development of which was funded by SRI. This was a true ground-to-air-to ground vehicle, designed to save long-distance commuters hours of travel on crowded roads. A hybrid of car, helicopter, and aeroplane it had a rotor on top, enabling near-vertical take-off and landings using roads rather than airports. Forward-swept wings and a pusher propeller at the rear enabled the Convertiplane to travel further and faster than a helicopter. In 1963 he applied to California's Senate Transportation Committee for permission to use his invention on public roads, and in 1964 they agreed, but objections from individual townships started piling up and political pressure saw the project dropped. Shoulders response to this was to create a new company called Vertitek, with the intention of developing remote-controlled drones for a wide variety of uses, from children's toys to crop dusting.

In 1968, after a decade spent at SRI, the forever restless Shoulders left to pursue this interest in experimental aircraft at his own expense, but as he saw it, free from bureaucratic restraint. In 1976, needing more substantial funding to pursue his plans Shoulders visited Hal Puthoff at SRI. This led to Puthoff organising a meeting with George “Bill” Church, the owner and CEO of a chain of shops called ‘Church’s Fried Chicken’, a Texas business man eager to fund research into new energy sources. They soon settled on a deal, Church would pay Shoulders a wage and fund his lab work, and in return Church would have a financial interest in Shoulders inventions. Eventually these two became friends as well as business partners.

Church and Shoulders together had the organisation, brains, and money needed to build a personal aircraft. Using experience gained from his drone program Shoulders built a prop-driven lightweight metal skeleton as the basis for his flying car. He also designed and built 2 hydrogen peroxide rockets that would allow vertical take-offs from a city street. Happily these were never used in earnest, but he flew his creation at low altitude around his property for fun sometimes, this and other projects occupied a decade of Shoulders life. In 1984 Church asked Shoulders to run a new hi-tech lab

he was building in Austin, Texas. This was to become the home of a commercial research enterprise called Jupiter Technologies, with Shoulders working as 'Chief Inventor' alongside Hal Puthoff\* and a group of scientists and technicians, all required to support Shoulders legendary creative energy. Jupiter gave birth to some successful (and unsuccessful) inventions, including a millimetre-wave generator and a new type of digital display. One aspect of the work that Shoulders and Puthoff did together focussed on electron condensed charge technology, research that eventually became known as EVOs and the main focus of Shoulders' work for the rest of his life.

Perhaps the freedom to explore his own interests, as well as financial security that Jupiter offered was too good to last. In 1989 Church began to run of money, although he was still in love with the Jupiter project. He delayed paying a promised \$10,000 bonus and started laying off staff. Part of the problem was that none of the lab's products were proving to be particularly profit. For a while Church tried to hide his money troubles but in 1990 Jupiter Technologies was shut down. Ken Shoulders spent another four years in the former Jupiter lab, finishing off contracts and working on EVO technology before returning to California in 1994. In 1995 he found a new financier, who was to fund him for the next 10 years. According to his son Steve Shoulders, "From a 30-minute meeting and a handshake agreement we moved to Free-stone."

#### WHAT ARE EVOs?

It seems possible that observations Shoulders made while working on electron-beam devices at SRI set in motion a train of thought that led to his work on creating, describing and categorising EVO's, which he described as clusters of perhaps hundreds of billions of electrons. At one point in his papers he mentions that the number of electrons in an EVO may be linked to Avogadro's Number. The quote below suggests he had been thinking about 'free flying' electrons for a long time.

*"...it is better to develop electronics with free flying electrons, than develop transistors, where the electron velocity is much slower due to the ion cores retracting the electrons in the solid material and semiconductors." Ken Shoulders in conversation.*

There is of course a huge fundamental objection to the idea that electrons, which all carry the same negative charge, could form any kind of close association. 'Unlike charges attract, like forces repel' is a fundamental maxim of classical physics. Shoulders discussed the EVO idea with Professor Feynman, who dismissed him as nuts initially, though later he wrote saying that there an explanation and some prior art\*, and that EVO theory was correct. There has also been work done on the theoretical underpinning of EVOs by Hal Puthoff, described in this paper:-

<https://arxiv.org/ftp/physics/papers/0408/0408114.pdf>

#### CHARGE CONFINEMENT BY CASIMIR FORCES. H. E. PUTHOFF AND M. A. PIESTRUP

##### ABSTRACT

*Laboratory observation of high-density filamentation or clustering of electronic charge suggests that under certain conditions strong coulomb repulsion can be overcome by cohesive forces as yet imprecisely defined. Following an earlier suggestion by Casimir, we investigate here the possibility that Casimir forces can lead to charge clustering of the type observed, and conclude that such forces may play a role in the generation of robust high-charge-density effects.*

\* Feynman discovered previous work on charge clusters had been done in 2 other laboratories.

KEN SHOULDERS EVO RESEARCH.

It is impossible in this short piece to describe or attempt to explain the huge body of work on EVOs that Ken Shoulders and his son Steve created , working for 25 years in a well-funded 4,000 square foot lab in California. An accessible description of his apparatus and some ancillary instruments is to be found in the paper, [below](#). Following the closure of the Ken Shoulders web archive, this particular document can no longer be found easily on the web, so a link to a pdf copy is appended.

APPARATUS FOR FORMATION AND USE OF EVOS KEN SHOULDERS © JULY 2, 2009

ABSTRACT.

The apparatus described here (is the result of) the integration of many component design iterations that have been tested both separately and in small systems. A useful design is (shown), a single piece of apparatus capable of both forming large EVOs and testing them for the generation of electrical power, propulsion and weaponry .....

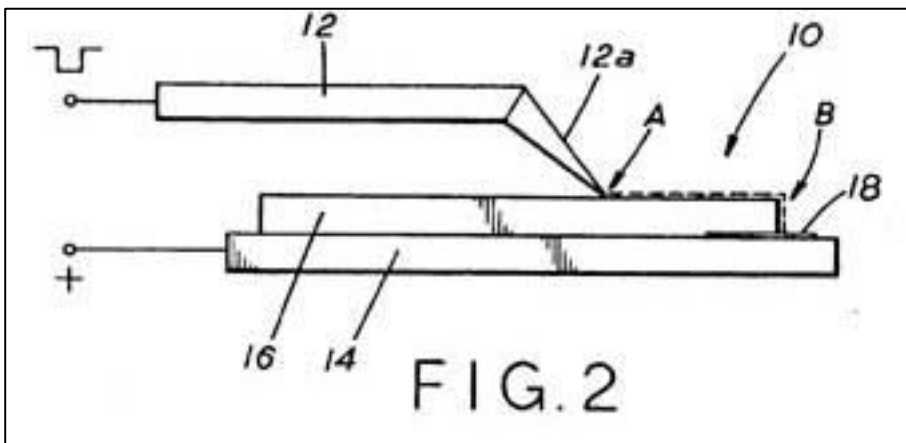

This diagram is taken from one of Shoulders patents, showing the device in its most basic form. It shows a sharply pointed electrode (12, 12a) sitting on a dielectric surface (16) supported by a conductive plate (18). A 'rapid rise' DC pulse is applied to the electrode and an EVO

chain passes between (A) and (18). A target in the form of a thin sheet of metal with various coatings may be positioned at (A). SEM examination of the target is used to provide evidence of an interaction. The small craters produced are the result of EVO impacts, analysis of the size

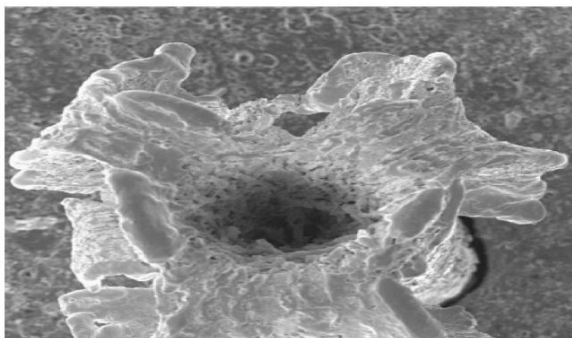

An example of an EV impact crater in metal shown in a paper presented at the MIT Cold Fusion Conference May 21, 2005 by Ken Shoulders.

and topology of these penetrations indicates the amount of energy deposited on the target foil. EVOs are firmly in the camp of exotic physics, some – including Ken Shoulders - see them as a connected to the Quantum Vacuum, sometimes called the Aether. This energy rich but highly speculative medium may offer a path to creating clean energy, if we only knew how. The EVO may also be a fundamental trigger mechanism involved in all kinds of LENR. It is possible that those searching for a LENR theory and to develop reliable systems should be looking at EVOs.

## THE NATURE OF EVOs.

Shoulders described EVOs as “a highly organized, micron-sized cluster of electrons... having soliton behaviour, with electron populations on the order of Avogadro’s number”. As previously stated, Avogadro’s number is  $6.23 \times 10^{23}$ . Describing the damage these clusters do when striking an oxidised aluminum foil target he said, “Using an ordinary thermal interpretation, a thermal gradient for bulk material greater than 26,000 degrees C per micrometer would be required to achieve these effects.” This suggests that 26,000C would be the temperature required to melt a clean hole right through material with a melting point of 2,600 degrees C. Photographs below show an EV impact crater in aluminium from a paper presented at the MIT Cold Fusion Conference May 21, 2005 by Ken Shoulders.

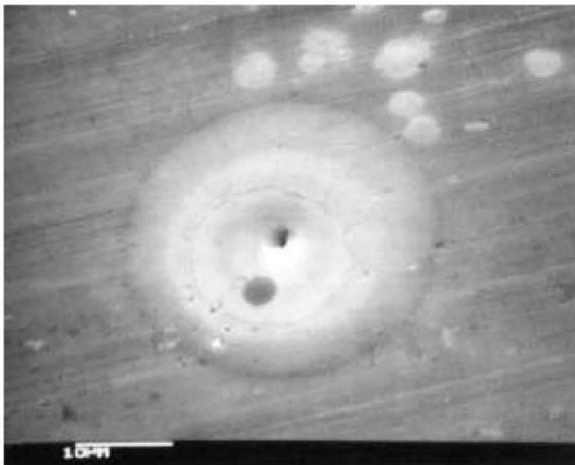

Fig. 1 EV strike on 6 micrometer thick aluminum foil.  
Entry side.

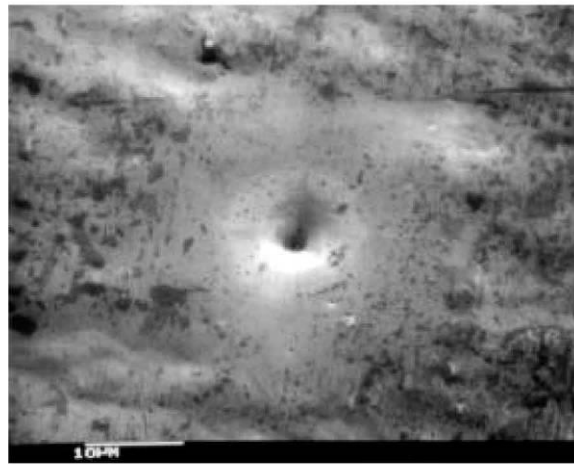

Fig. 2 EV strike on 6 micrometer thick aluminum foil.  
Exit side.

### SHOULDERS' FURTHER NOTES ON EVO FORMATION AND CHARACTERISTICS

‘In the simplest of EVO formation methods, electrons are extracted from a conductor by quantum mechanical tunneling when applying sufficiently high fields to exceed what is termed the space charge limit of emission.

In this trans-space charge region, electrons are emitted as a coherent stream of fluid having number densities equal to that of the conductor lattice template, being in the region of Avogadro’s number. The fluid-like properties of this emergent stream, along with incidental electrodynamic forces, determine how much emission occurs before quenching, hence, the size and spherical shape of individual, emergent EVO’s as well as the stream flow properties producing the bound and entwined groups of entities emitted. In this scenario, the foundation properties of the EVO always existed within the confines of the conductor lattice. When the electron substance is pulled from the lattice by intense fields, a new container form must be found.’

The references above to ‘bound and entwined, and ‘a new container form’ are related to Shoulders conclusion, reached after thousands of hours of careful bench testing and direct and indirect observation that discrete EVOs are toroidal in form, and these can then form chains of intertwined toroids. A remarkable thought.

## IS THIS KNOWLEDGE USEFUL?

The title of this paper refers to Shoulders' maverick reputation, something compounded by the fact that he was in many ways not the most sociable of men. His lack of more than a high-school formal education, his scattershot CV and the company he kept. Even Hal Puthoff, his colleague at SRI, was somewhat suspect due to his interest in parapsychology and connections to Uri Geller. Shoulders also became friends with John Hutchison, who is at the furthest end of the 'wild and questionable science' spectrum. But these were not the only relationships he developed; other friends of many years standing were more conventional scientists

Despite a tendency to grouchiness, Ken was a superb craftsman, gifted experimenter and visionary thinker who commanded respect tinged with occasional awe from many people. His unorthodox approach was both the stimulus for and the result of his openness to unusual ideas. He never dismissed something new out of hand; he thought about it and if the thinking was positive, tested it. One thing many of his friends and colleagues often remarked on is that his scientific ideas were 'almost never wrong.'

Ken convinced many (but not all) that the EVO phenomenon is real, in spite of the like charge repulsion difficulty. In his own words "Nobody believed anything (I) ever said. They only believed the gadgets that were run by EVs. I actually had to almost beat the patent office into submission by a series of brutal assaults with my devices!"

It is worth remembering that Ken was sure that EVOs offer a connection to the basic fabric of the universe by biasing the medium with a dense, asymmetrical charge distribution." This is a very powerful concept and may well be the foundation of any device that operates with an "efficiency" (that indicates) over-unity."

Ken Shoulders also believed that EVO's were capable of transforming into mini Black Holes, or in their various manifestations (all EVOs are not the same) could be harnessed for: Unlimited Energy production, Antigravity, Propulsion, Transmutation, Teleportation, Unimaginable destructive capability. Quite a list.

### References:

Article: K. Shoulders. Issue 75 of 'Infinite Energy'. <http://www.infinite-energy.com> magazine.

K. R. Shoulders, EV-- A Tale of Discovery, Austin, TX, 1987. A historical sketch of early EV work having: 246 pages, 153 photos and drawings, 13 references.

U.S. Patents issued to K. R. Shoulders related to EVOs. 5,018,180 (1991) - 5,054,046 (1991) - 5,054,047 (1991) - 5,123,039 (1992), and 5,148,461 (1992).

H. E. Puthoff et al. Electronic Devices Using Discrete, Contained Charged Particle Bundles and Sources of Same U.S. Patent No. 5,208,844. May 4, 1993

G. A. Mesayets and D. I. Proskurovsky, Pulsed Electrical Discharge in Vacuum. Springer-Verlag, New York, 1989.

V. Nardi, W. H. Bostick, J. Feugas, and W. Prior, Phys. Rev. A 22, 2211. 1980.

Remediation of Radioactive Emissions in Spent Nuclear Fuels using High Density Charge Cluster [EVO] Techniques [http://blog.hasslberger.com/docs/EVO\\_Nuclear\\_Remediation.pdf](http://blog.hasslberger.com/docs/EVO_Nuclear_Remediation.pdf)

H. B. G. Casimir, Physica 19, 846 (1953).

Article: [http://blog.hasslberger.com/2007/10/ken\\_shoulders\\_evos\\_exotic\\_vacu.html](http://blog.hasslberger.com/2007/10/ken_shoulders_evos_exotic_vacu.html)

Article: <https://www.chemheritage.org/distillations/magazine/the-frontiersman>

The Kenneth Shoulders Archive is in storage at the Chemical Heritage Foundation Library, USA.

Bob Greenyer of MFMP has created a transcript of Kenneth Shoulders & John Hutchison's 2010 meeting where they talked about the near infinite potential of "Charge Clusters" also known as "Exotic Vacuum Objects" (EVO) also known as "Condensed Plasmoids". The video is also available.

<https://steemit.com/dtube/@mfmp/nzssv2y3>

